

Container shelter/ Containerüberdachung / Abris sur containers

# KROFTMAN CT-S-1206

Assembly manual for main frame  
Montageanleitung für den Hauptrahmen  
Manuel d'assemblage du cadre principal

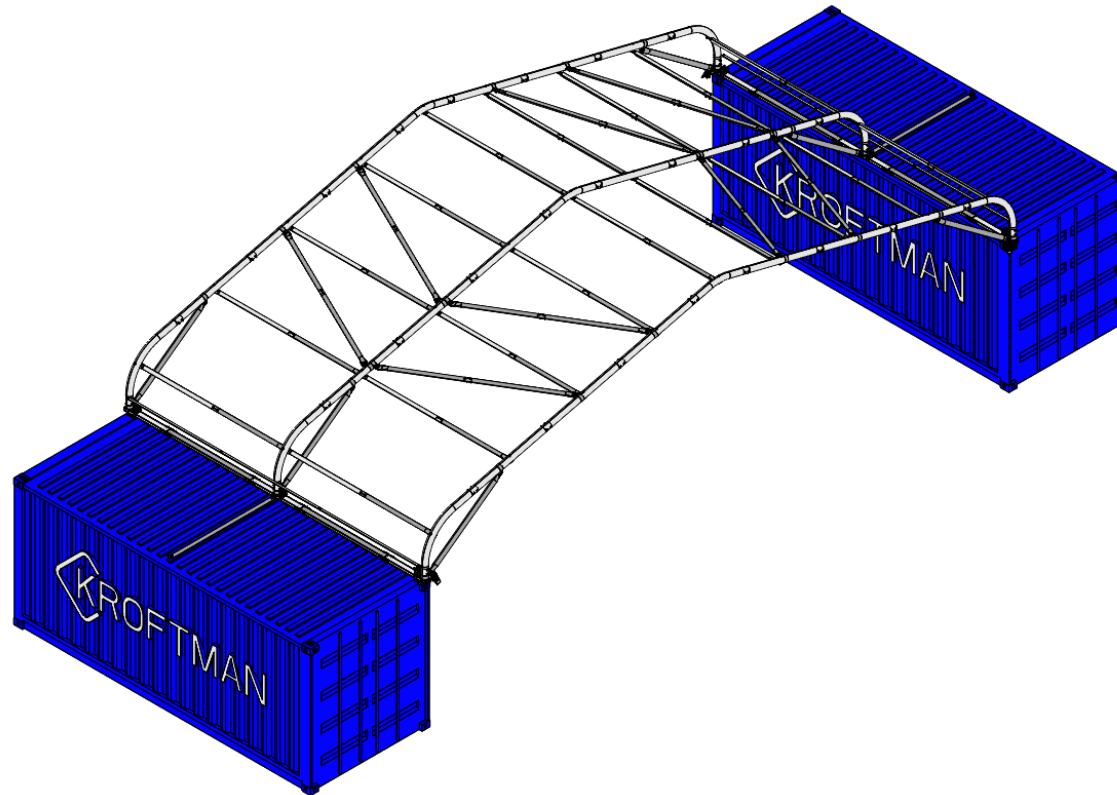



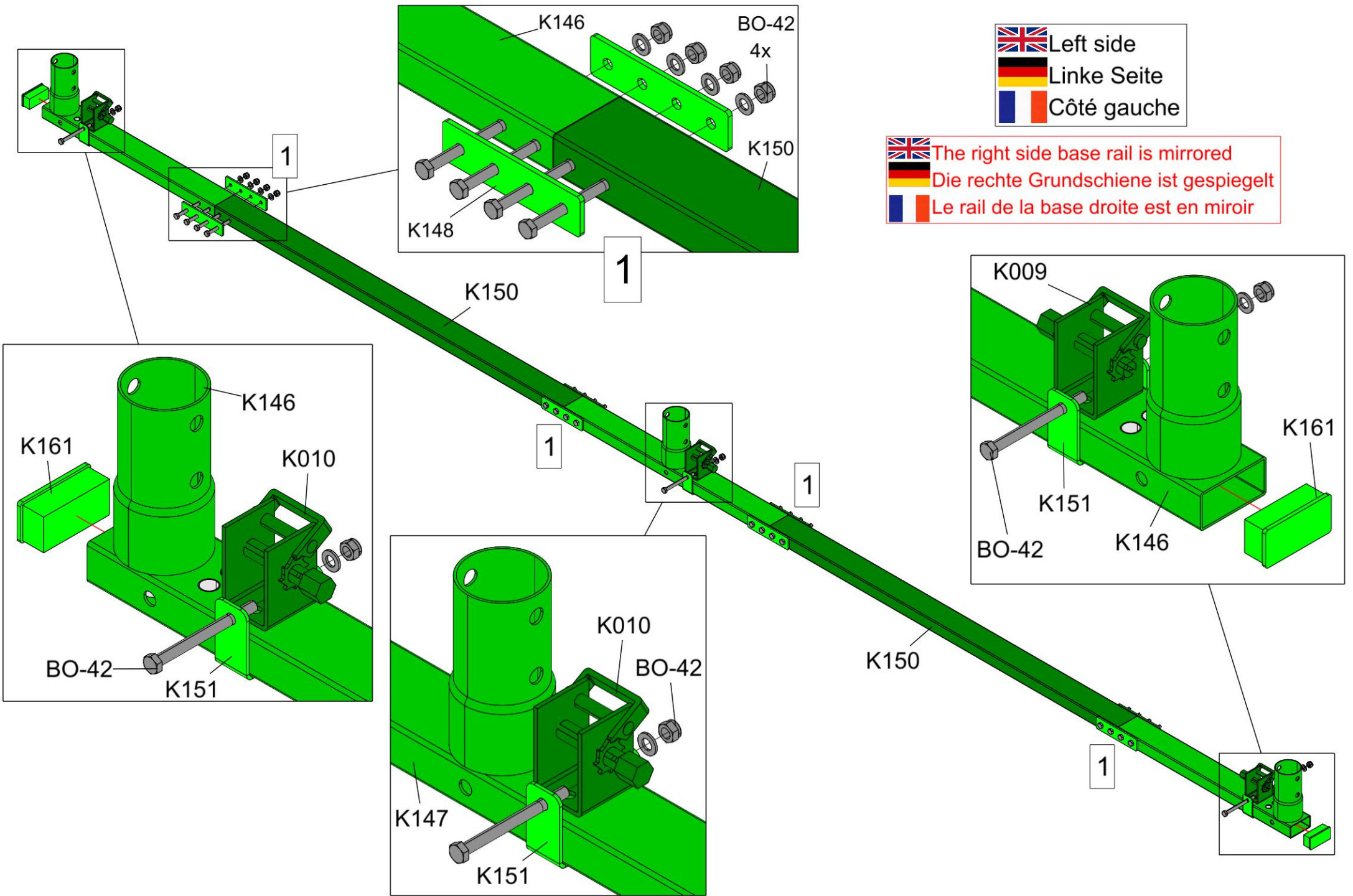



 Left side  
 Linke Seite  
 Côté gauche

 The right side base rail is mirrored  
 Die rechte Grundschiene ist gespiegelt  
 Le rail de la base droite est en miroir

 Place and symmetrically align the base rail on top of the container. Mark the position of the K145-2 clamps as close to the tubes as possible, remove the base rail and place the clamps. Level the clamps and tighten the nuts hand-tight.

 Setzen Sie die Grundschiene auf den Container und richten Sie sie symmetrisch aus. Die Position der K145-2-Klemmen so nah wie möglich an den Rohren markieren, die Grundschiene entfernen und die Klemmen anbringen. Richten Sie die Klemmen aus und ziehen Sie die Muttern handfest an.

 Placer et aligner symétriquement le rail de base sur le dessus du conteneur. Marquer la position des pinces K145-2 le plus près possible des tubes, retirer le rail de base et placer les pinces. Mettez les pinces à niveau et serrez les écrous à la main.

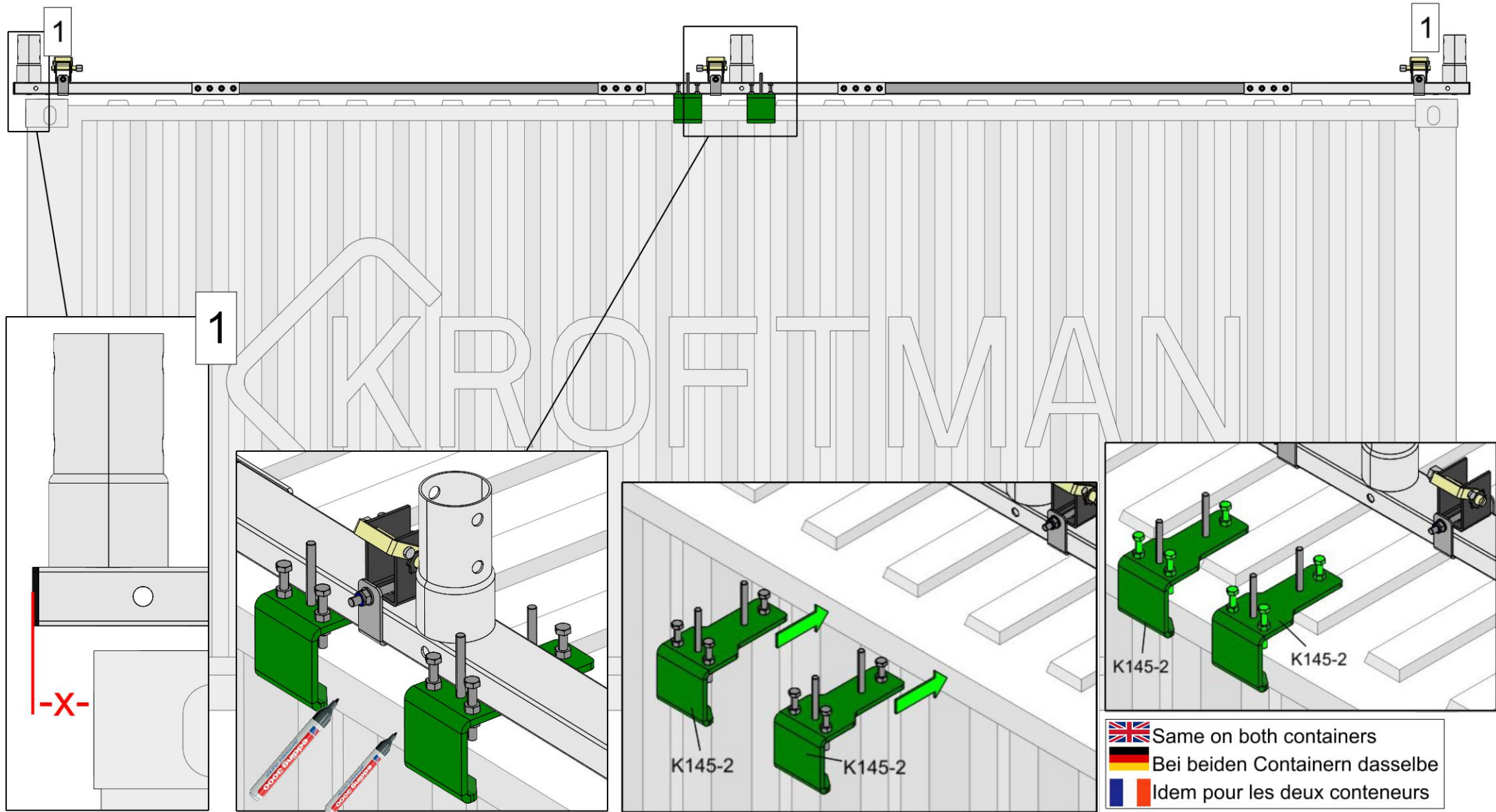



 Install the plate and secure everything by tightening the nuts hand-tight.

 Montieren Sie die Platte an und sichern Sie alles, indem Sie die Muttern handfest anziehen.

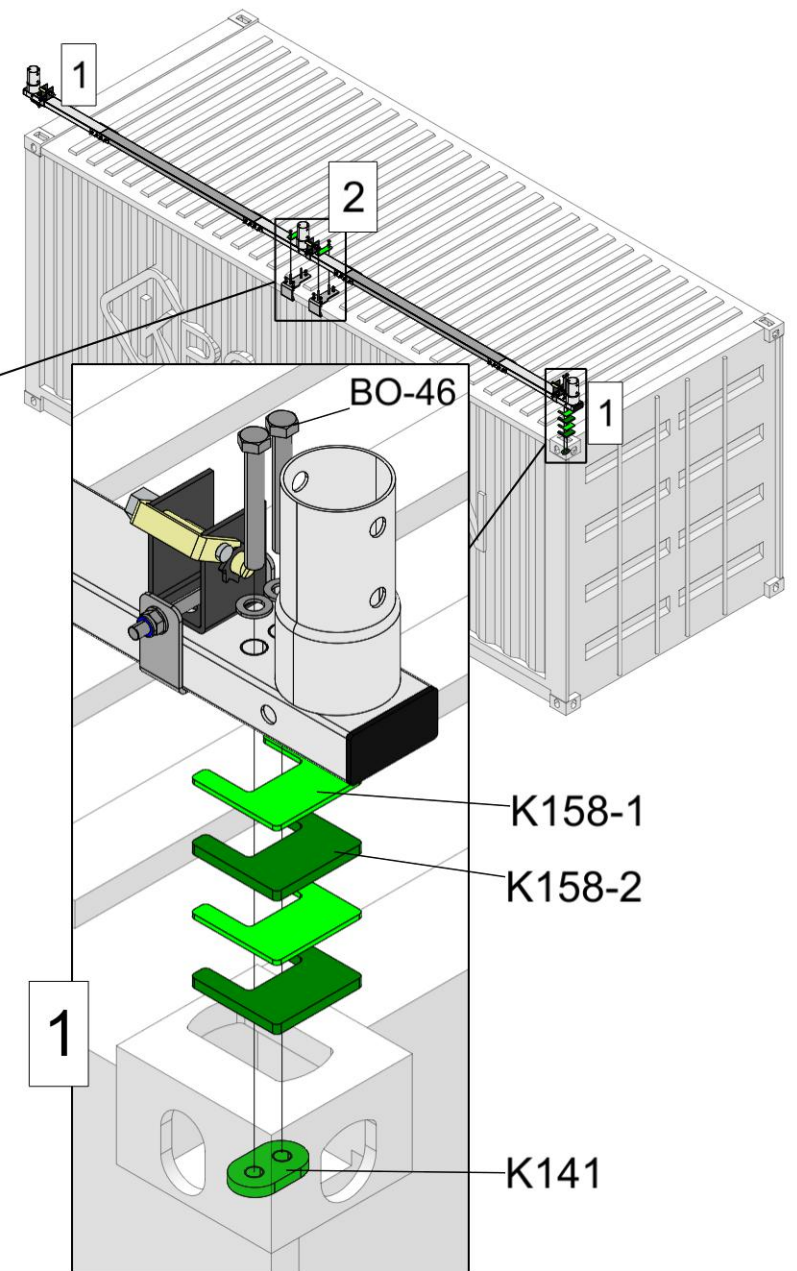
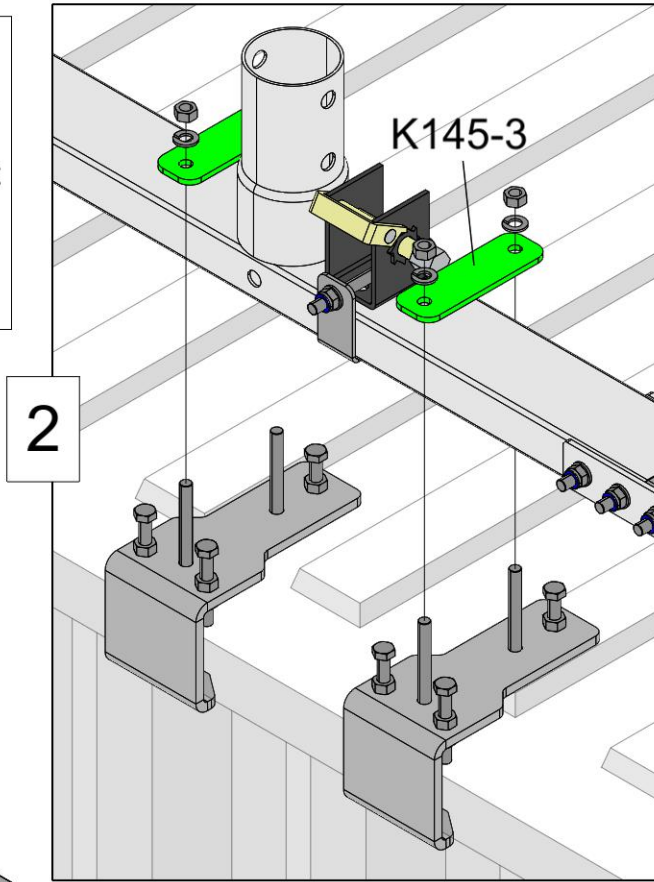
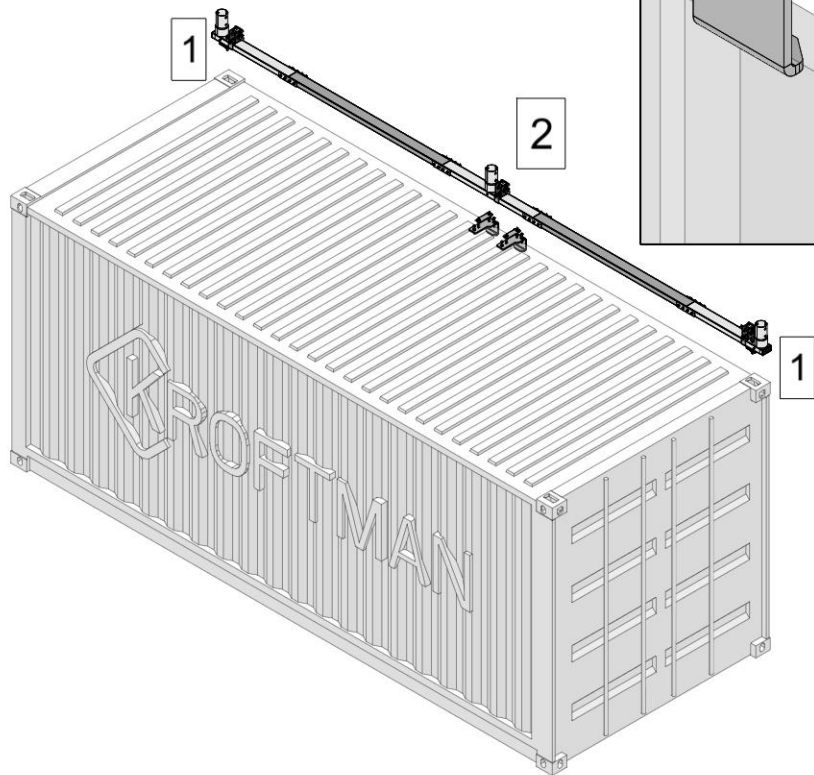
 Installez la plaque et fixez le tout en serrant les écrous à la main.



 In the corners, use the combinations of plates that fits best.

 Verwenden Sie in den Ecken die Kombinationen von Platten, die am besten passen.

 Dans les coins, utilisez les combinaisons de plaques qui conviennent le mieux.

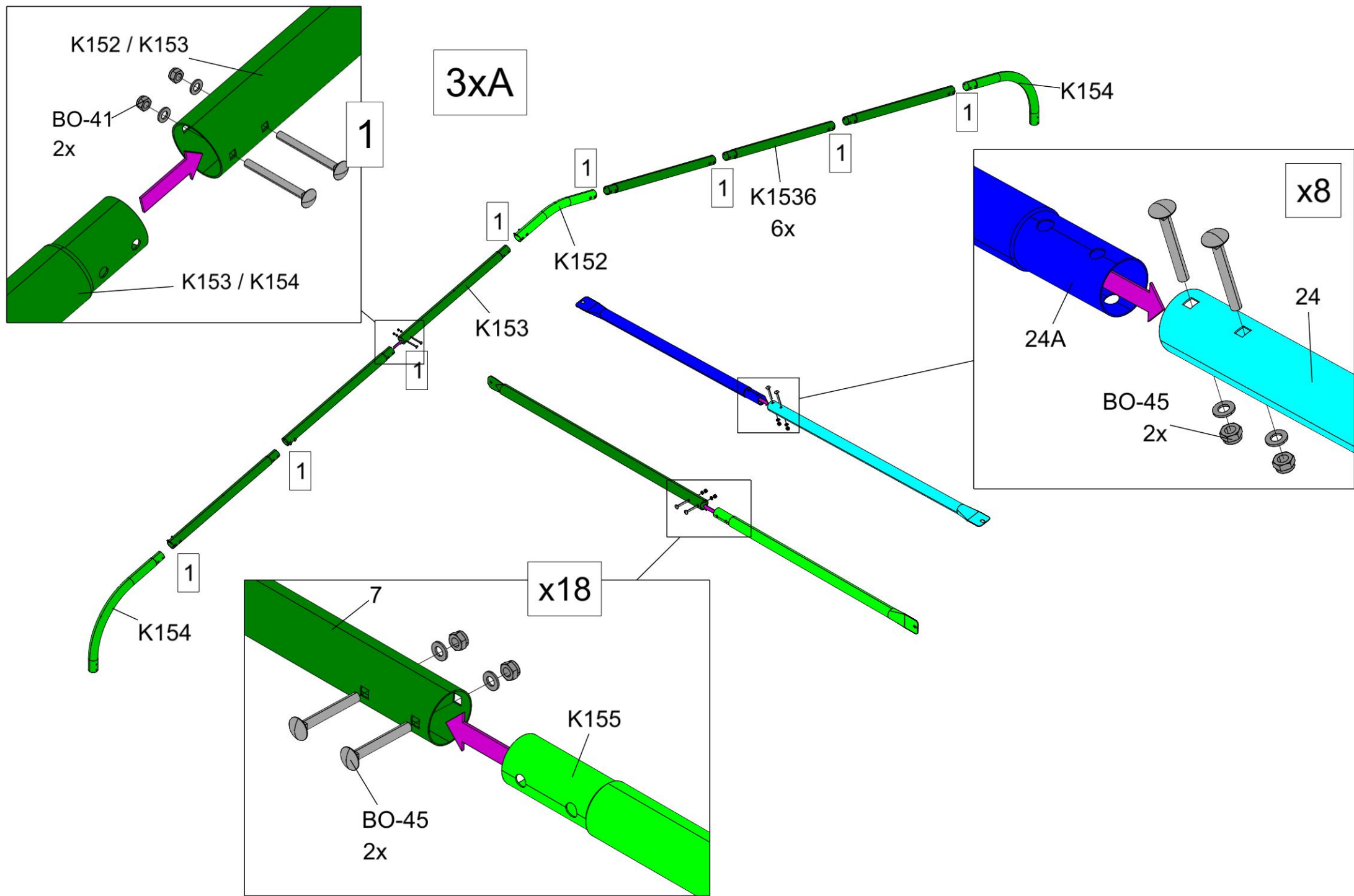



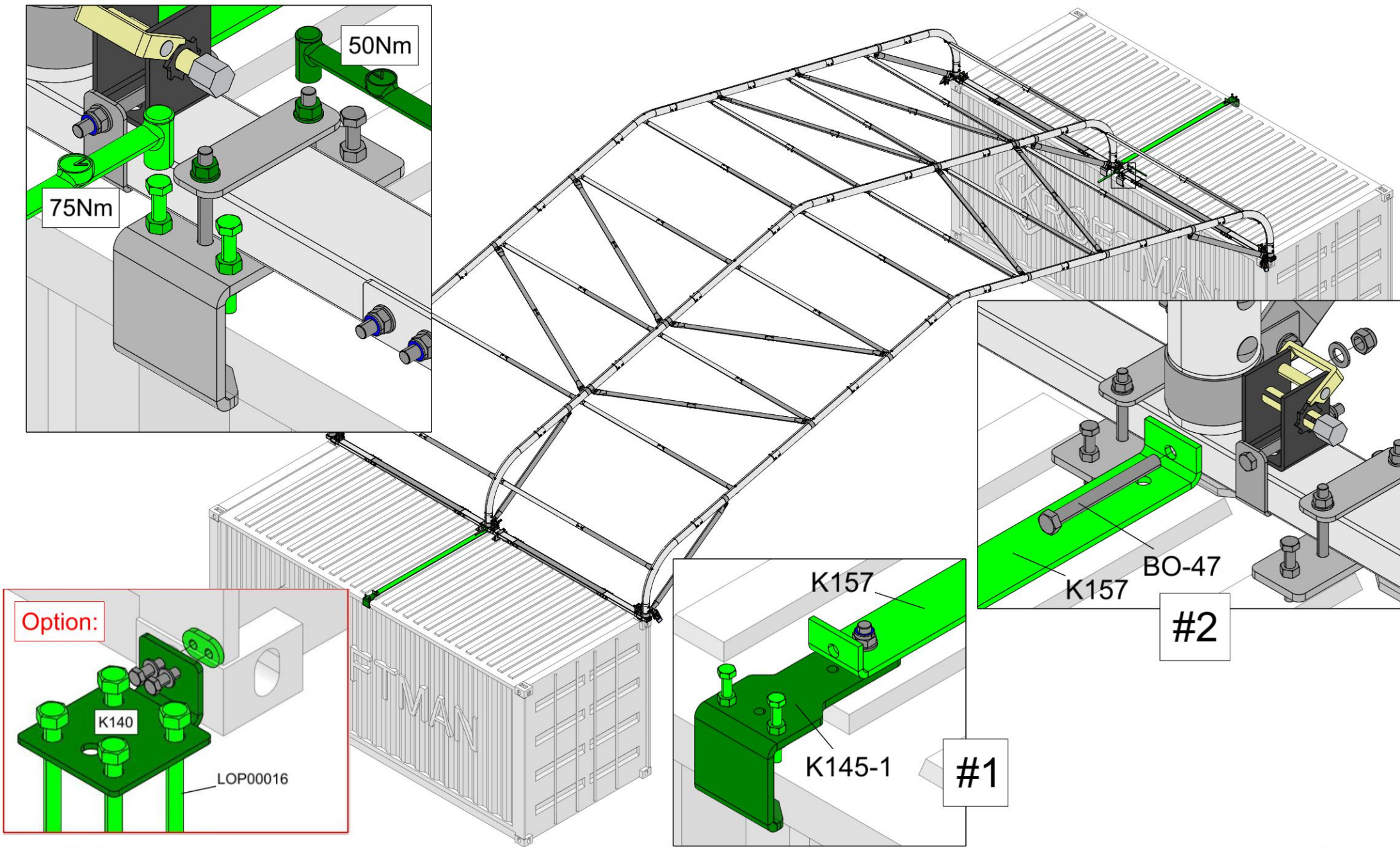

 Important: add permanent weight in containers according to calculations or use optional container anchoring bracket.

 Wichtig: Fügen Sie den Containern ein dauerhaftes Gewicht gemäß den Berechnungen hinzu oder verwenden Sie die optionalen Container- Verankerungskammern.

 Important : ajoutez le poids permanent dans les conteneurs selon les calculs ou utilisez le support d'ancrage de conteneur en option.