

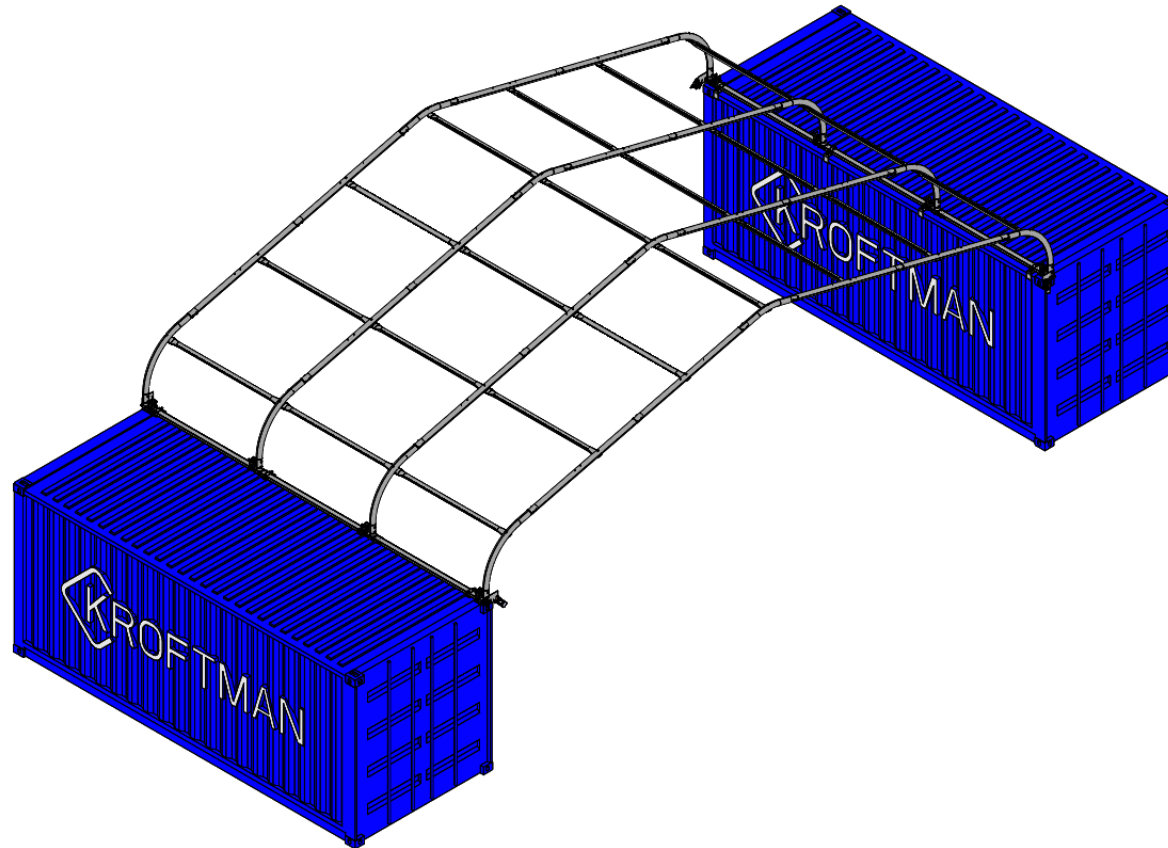

Container shelter/ Containerüberdachung / Abris sur containers



KROFTMAN CT-S-1006

Assembly manual for main frame
Montageanleitung für den Hauptrahmen
Manuel d'assemblage du cadre principal



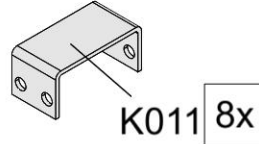
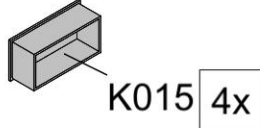
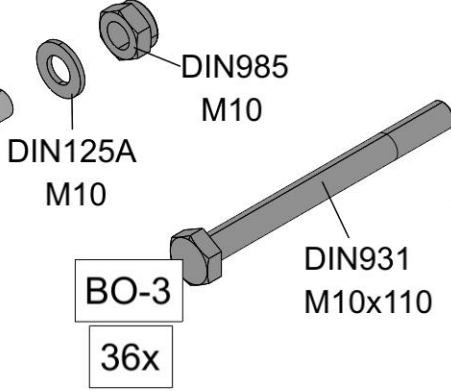
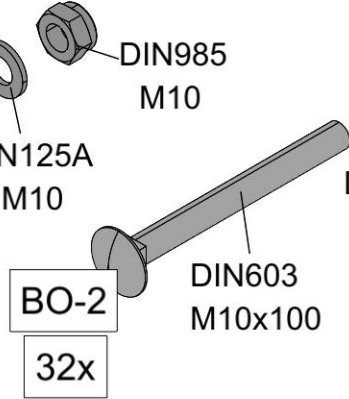
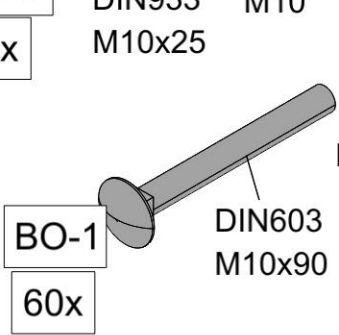
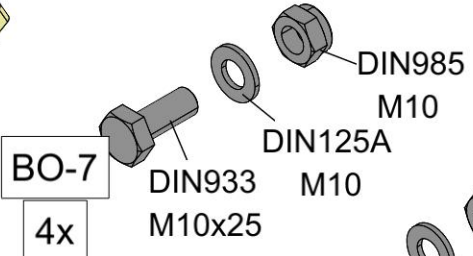
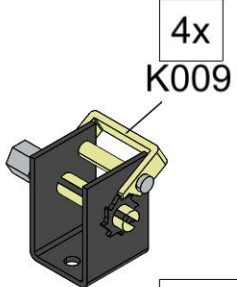
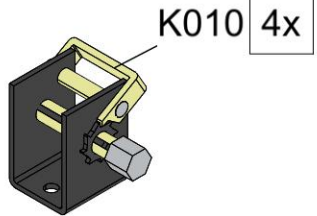
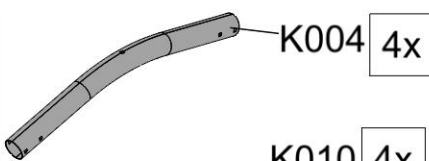
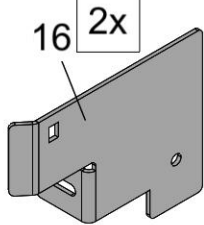
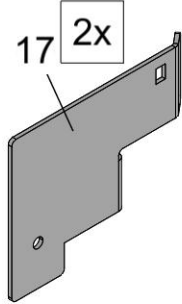
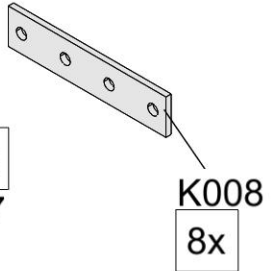
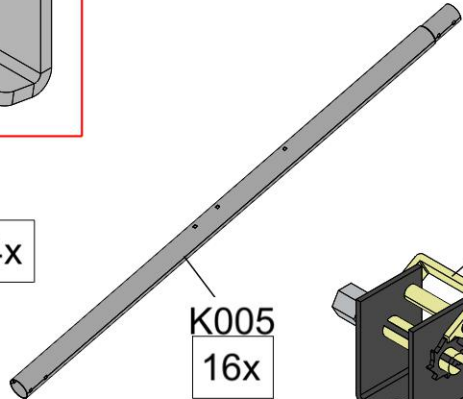
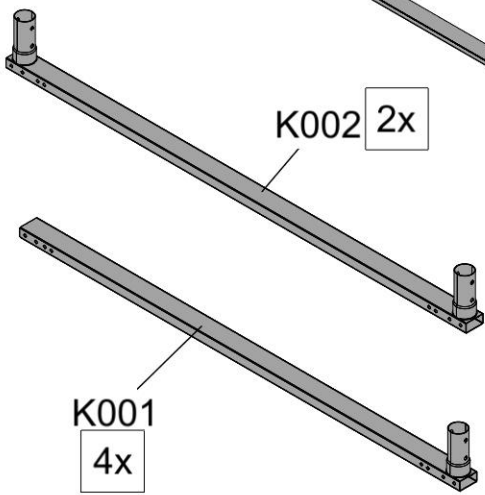
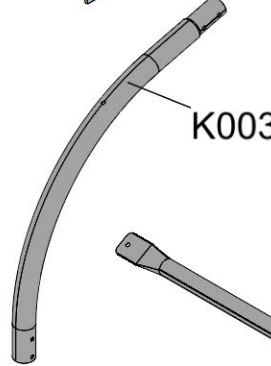
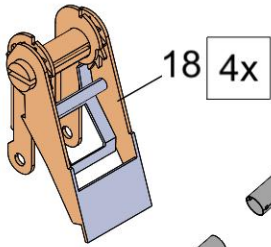
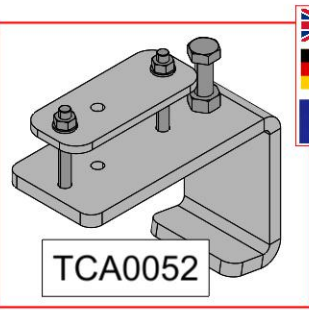

 Extra option
 Zusätzliche Option
 Option supplémentaire

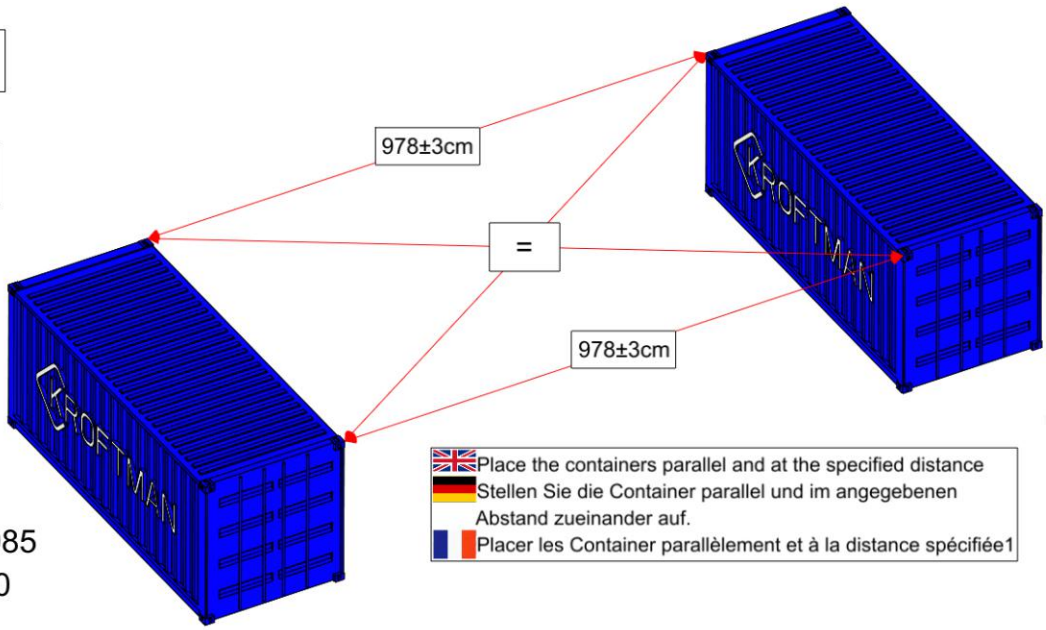
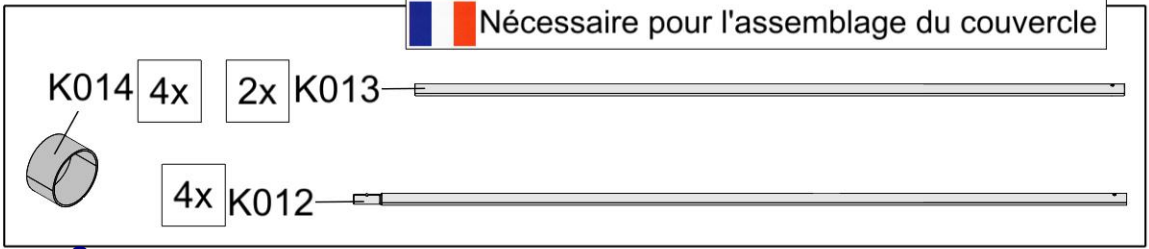

 Needed for cover assembly
 Erforderlich für die Montage der Abdeckung
 Nécessaire pour l'assemblage du couvercle





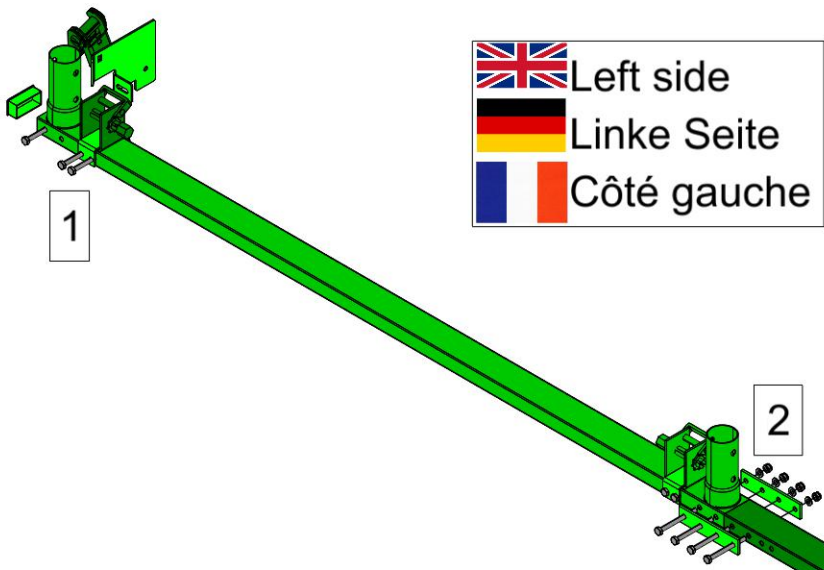

 Place the containers parallel and at the specified distance
 Stellen Sie die Container parallel und im angegebenen Abstand zueinander auf.
 Placer les Container parallèlement et à la distance spécifiée1

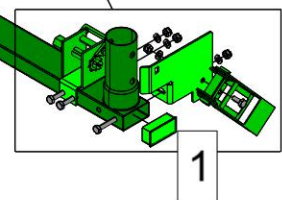
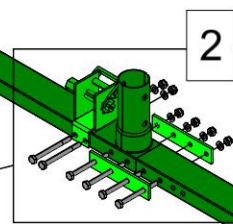
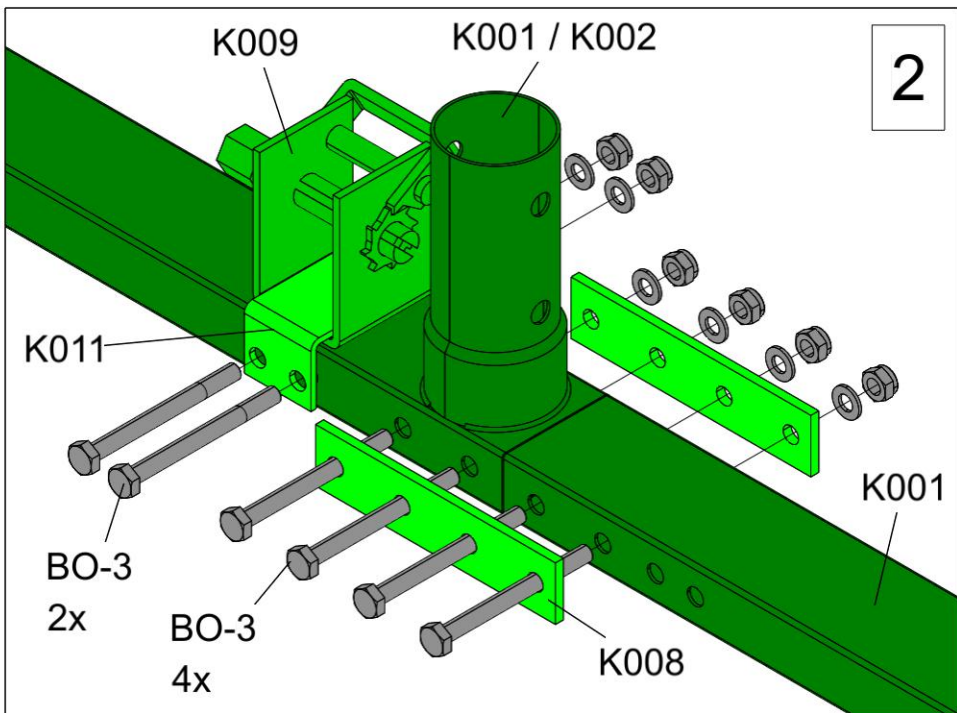
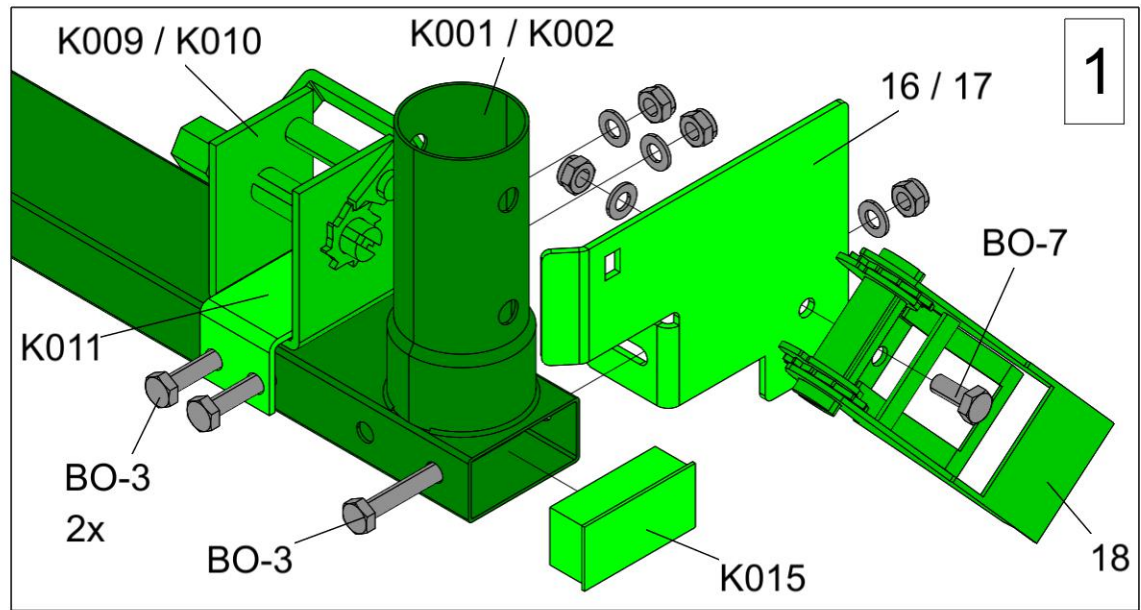

 Left side
 Linke Seite
 Côté gauche



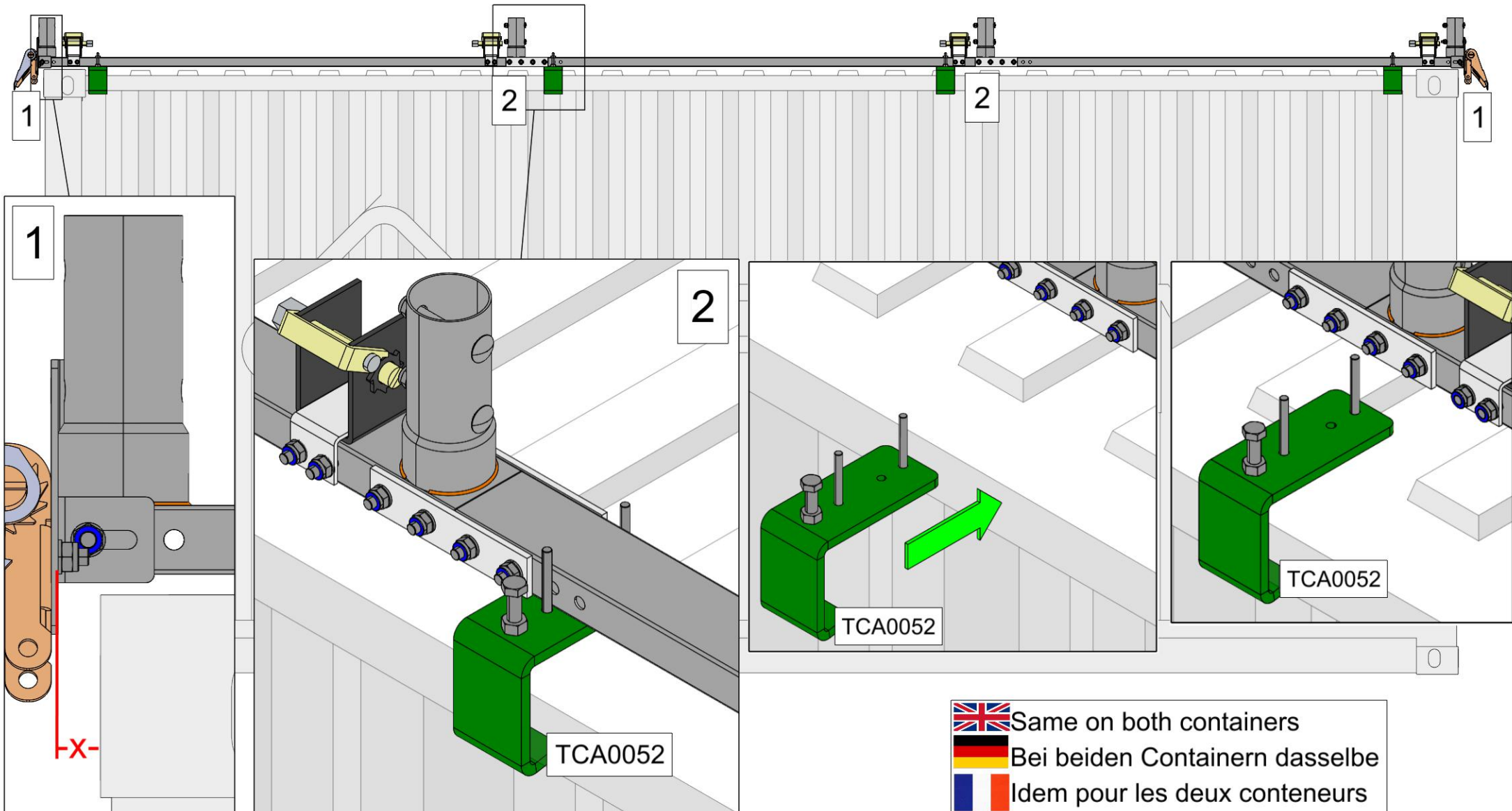

 The right side base rail is mirrored
 Die rechte Grundschiene ist gespiegelt
 Le rail de la base droite est en miroir

-  Place and symmetrically align the base rail on top of the container. Mark the position of the TCA0052 clamps as close to the tubes as possible, remove the base rail and place the clamps. Level the clamps and tighten the nuts hand-tight.
-  Setzen Sie die Grundschiene auf den Container und richten Sie sie symmetrisch aus. Die Position der TCA0052-Klemmen so nah wie möglich an den Rohren markieren, die Grundschiene entfernen und die Klemmen anbringen. Richten Sie die Klemmen aus und ziehen Sie die Muttern handfest an.
-  Placer et aligner symétriquement le rail de base sur le dessus du conteneur. Marquer la position des pinces TCA0052 le plus près possible des tubes, retirer le rail de base et placer les pinces. Mettez les pinces à niveau et serrez les écrous à la main.

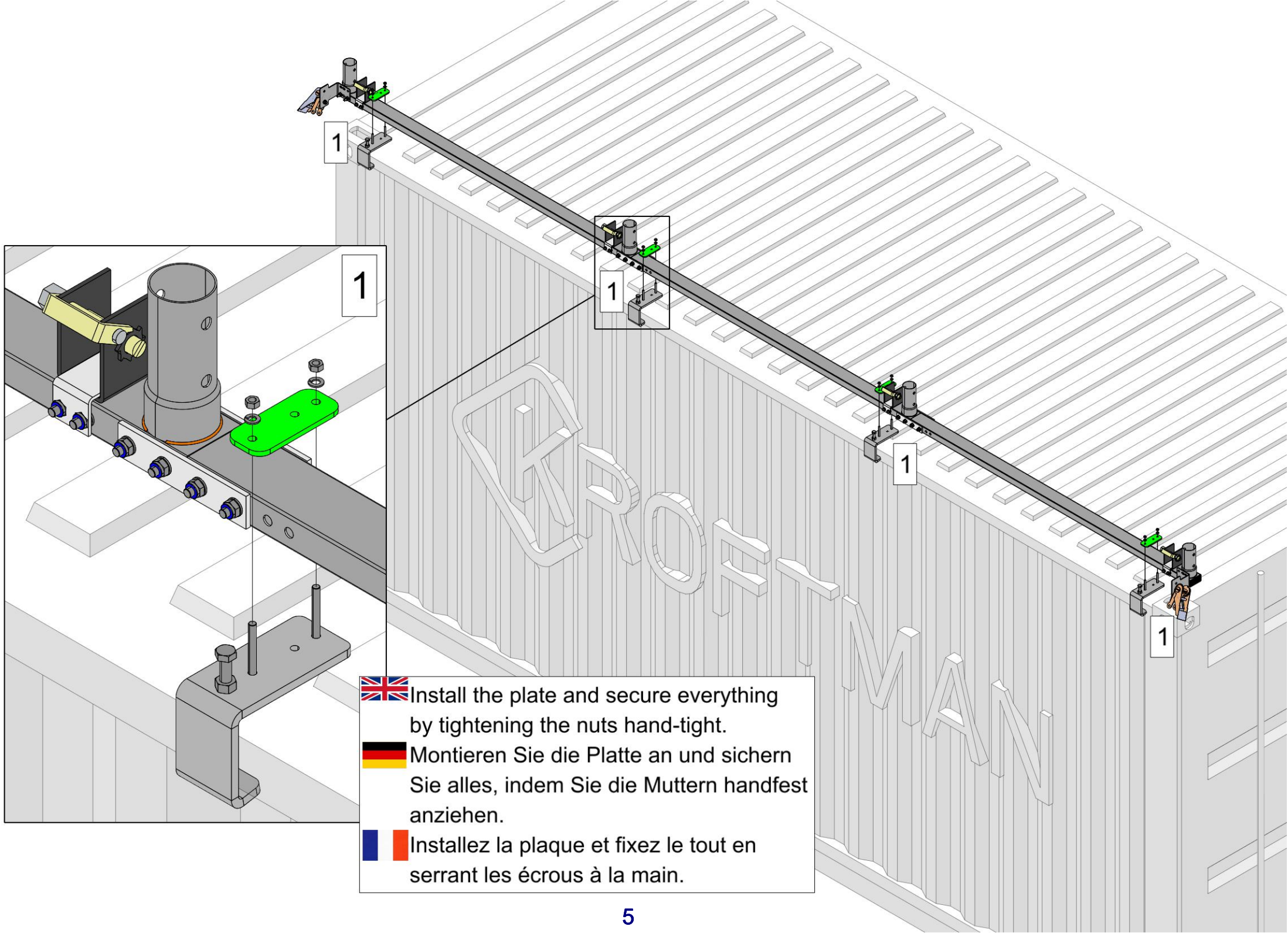





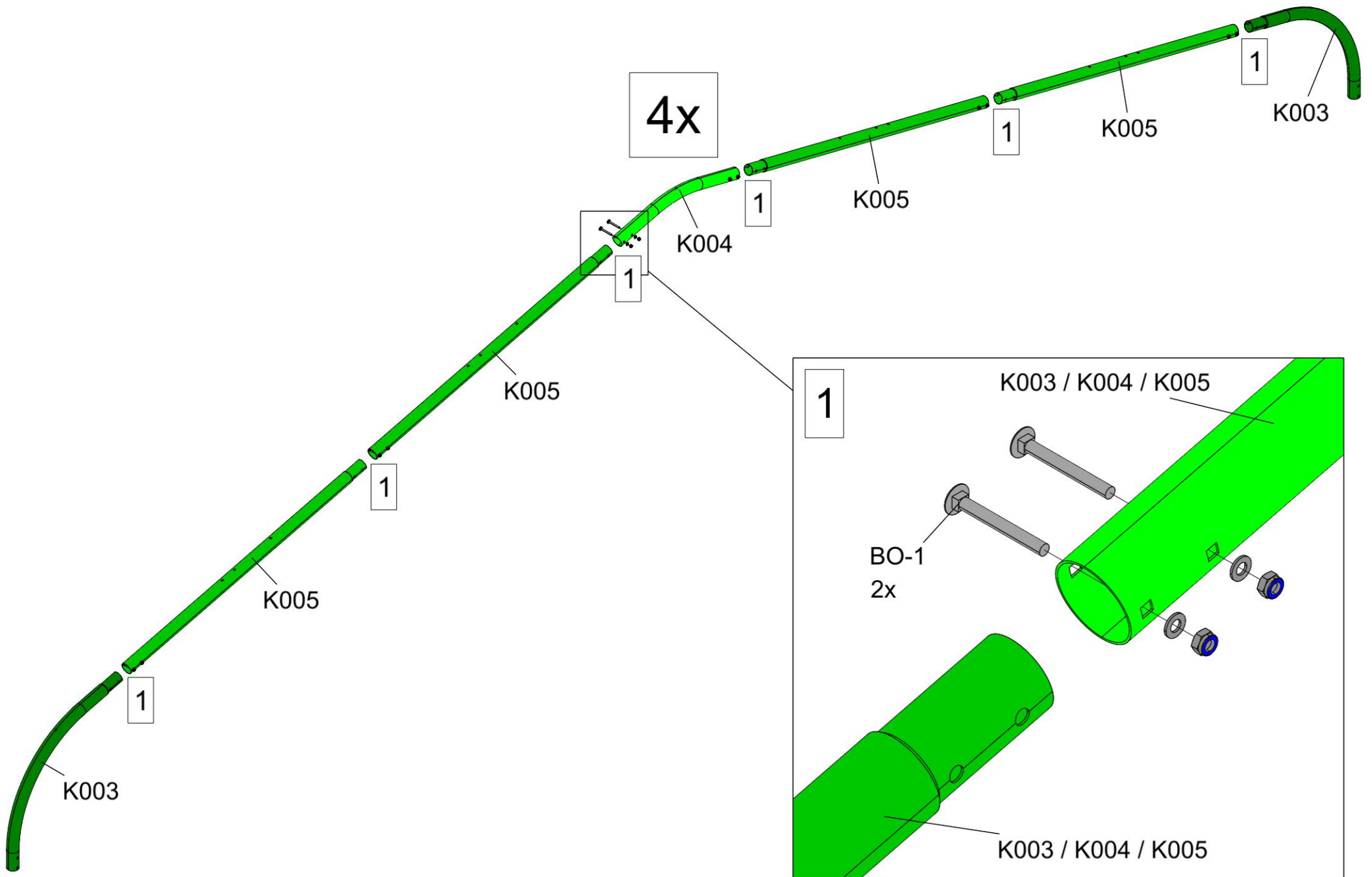

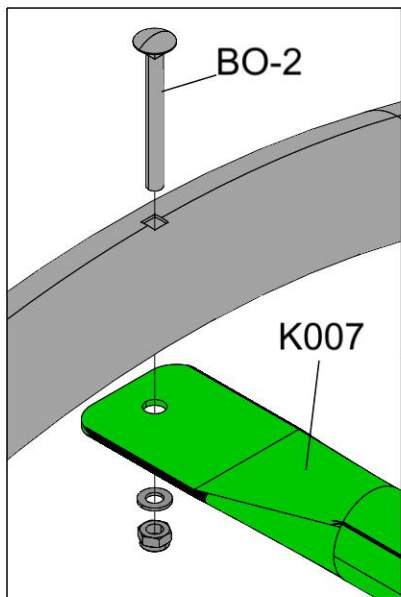
-  Install the plate and secure everything by tightening the nuts hand-tight.
-  Montieren Sie die Platte an und sichern Sie alles, indem Sie die Muttern handfest anziehen.
-  Installez la plaque et fixez le tout en serrant les écrous à la main.



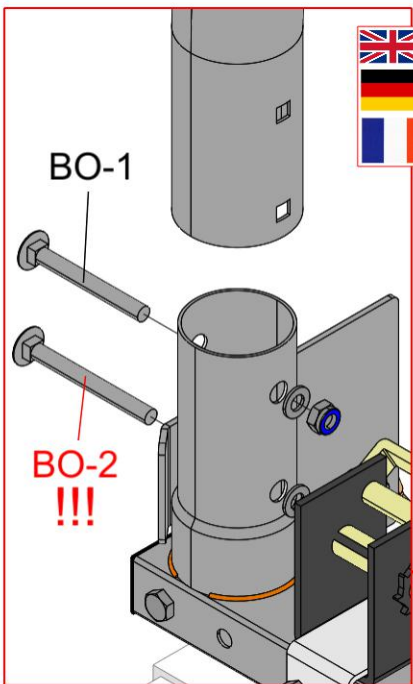
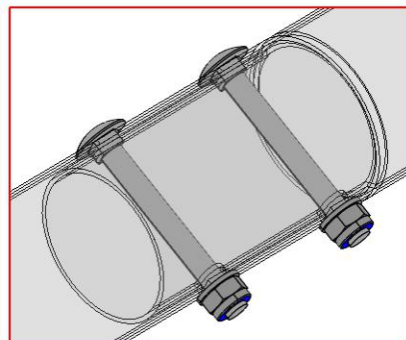

 When placing the first and last arch make sure the boltheads point outwards
 Achten Sie beim Anbringen des ersten und letzten Bogens darauf, dass der Schraubenkopf nach außen zeigt.
 Lorsque vous placez le premier et le dernier arc, veillez à ce que la tête de boulon soit orientée vers l'extérieur.





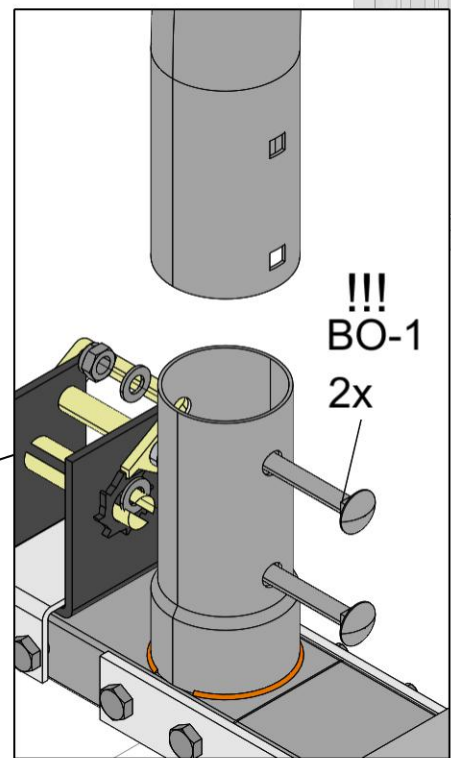

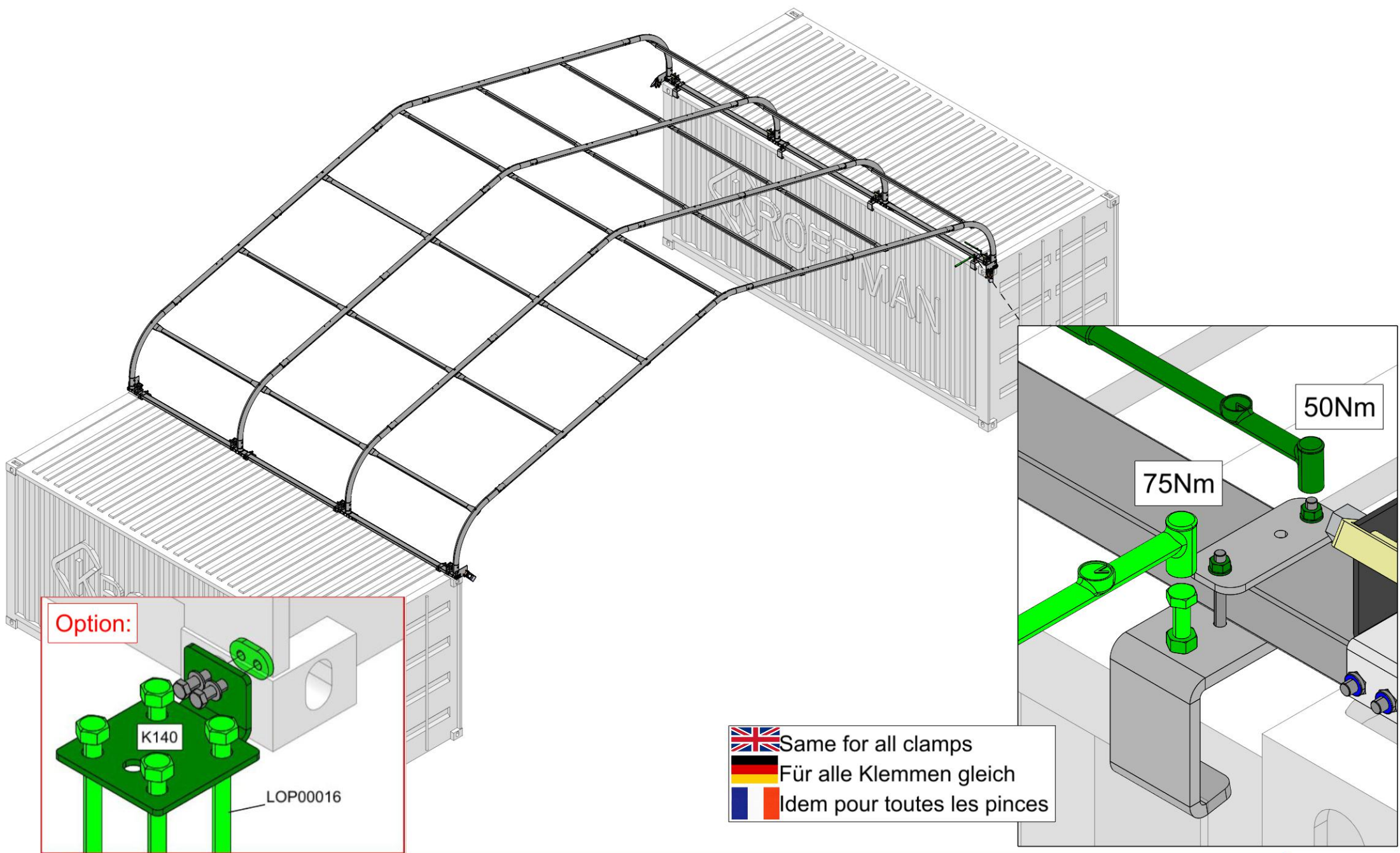
 Front and last arch only
 Nur vorderer und letzter Bogen
 Avant et dernier arc seulement



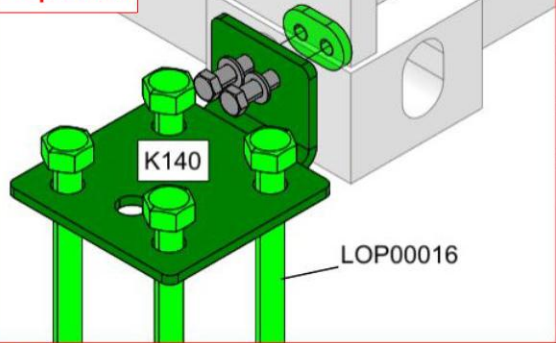



Option:



 Same for all clamps
 Für alle Klemmen gleich
 Idem pour toutes les pinces

 Important: add permanent weight in containers according to calculations or use optional container anchoring bracket.
 Wichtig: Fügen Sie den Containern ein dauerhaftes Gewicht gemäß den Berechnungen hinzu oder verwenden Sie die optionalen Container- Verankerungsklemmen.
 Important : ajoutez le poids permanent dans les conteneurs selon les calculs ou utilisez le support d'ancrage de conteneur en option.